



### Main Features

- Directly integrated in the pipe
- Mounted between 2 flanges
- Wetted parts 1.4571 (316Ti) or 1.4404 (316L)
- Easy and fast installation

### Applications

- Oil & Gas
- Chemical industry
- Water & Waste water
- Energy

### Description

This in-line diaphragm seals are used to protect pressure gauges from high temperature, aggressive or corrosive fluids. Due to the integration as part of the pipe line these seals are especially suitable for fluids with high viscosity or a tendency to crystallize.

Diaphragm seals can be mounted to mechanical pressure gauges, switches or transmitters directly or with a flexible capillary. The filling fluid of the measuring system has to be chosen compatible to the application.

Process connection	Mounting between flanges with FF or RF flange face (types A, B, C, D, E according DIN 2526)
Pressure ranges	0 ... 1 bar to 0 ... 40 / 250 bar (see table below)
Body material	Stainless Steel 1.4571 (316Ti)
Diaphragm	Stainless Steel 1.4571 (316Ti) or 1.4404 (AISI 316L)
Working temperature	-20 ... 225 °C (depending on the filling fluid)
Filling fluids	LRS1: Vaseline (-15 ... +150 °C) Other filling fluids on request
Gaskets	Not included

### Ordering code / Minimum pressure ranges

Code	DN	Pressure gauges <sup>(1)</sup>		Transmitters <sup>(2)</sup>	P max. <sup>(3)</sup>
		NS 50 / 63 mm	NS 100 / 150 / 160 mm		
1653	25	0 ... 4 bar	0 ... 4 bar	0 ... 1 bar	40 / 250 bar
1655	40	0 ... 1.6 bar	0 ... 1.6 bar	0 ... 1 bar	40 / 250 bar
1656	50	0 ... 1.6 bar	0 ... 1.6 bar	0 ... 1 bar	40 / 250 bar
1657	65	0 ... 1.6 bar	0 ... 1.6 bar	0 ... 1 bar	40 / 250 bar
1658	80	0 ... 1.6 bar	0 ... 1.6 bar	0 ... 1 bar	40 / 250 bar
1659	100	0 ... 1.6 bar	0 ... 1.6 bar	0 ... 1 bar	40 / 250 bar

<sup>(1)</sup> and corresponding compound pressure ranges

<sup>(2)</sup> lower pressure ranges on request

<sup>(3)</sup> depending on the pressure limitation of the used flanges and gaskets (not part of the delivery).

## Dimensions

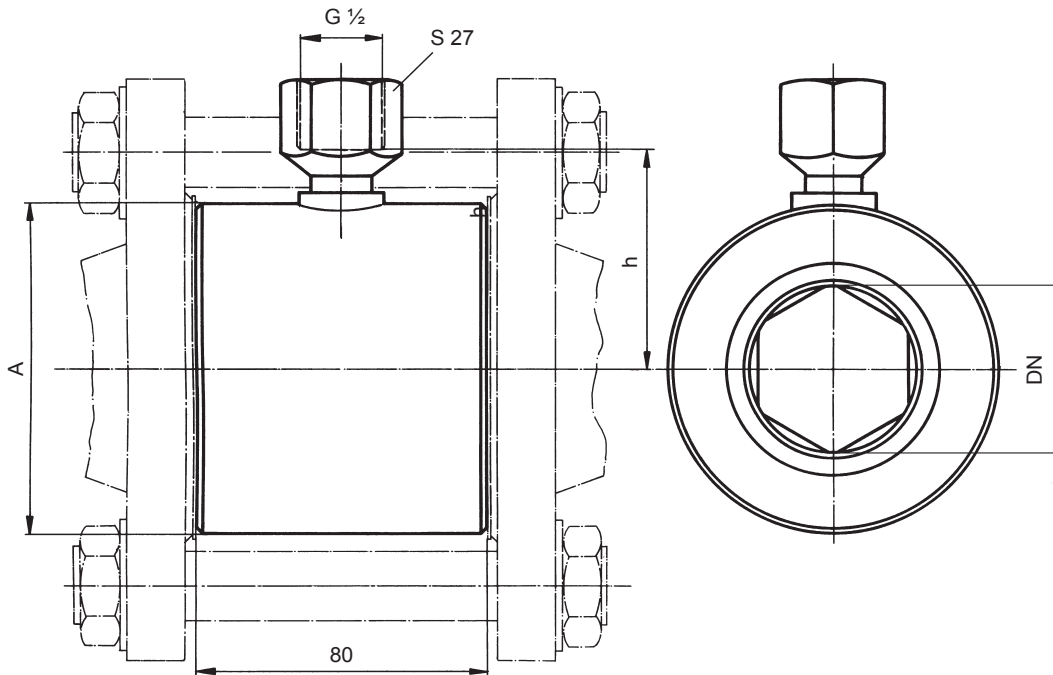

Dimension chart

DN	A	h (standard)	h (long extension)	Weight kg	Inner shape
25	63	42	82	1.8	6-sided
40	85	53	93	2.8	6-sided
50	95	58	98	3.6	6-sided
65	115	68	108	4.8	8-sided
80	130	75	115	5.5	8-sided
100	148	84	124	6.4	8-sided

## Ordering example

MEX 5 - D 3 0 . B22 / 1653 - 9007 - 0125 - LRS1

In-line diaphragm seal, DN 25

Option: Adjustment at specific fluid temperature

Adjustment temperature: 125°C

Filling fluid LRS1: Vaseline (-15 ... +150 °C)